

Dimensioning of keyway in the shaft and in the hub

Dimensions [mm]

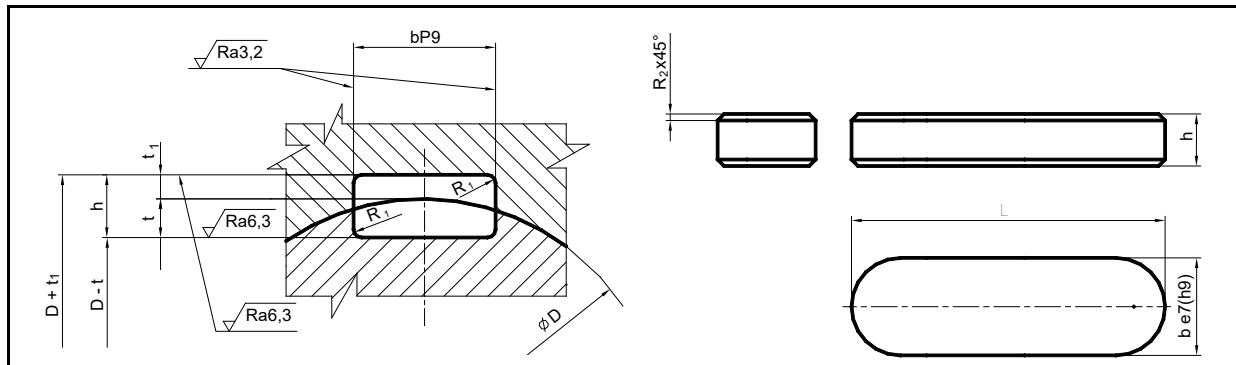

| D | | Keyway depth | | | | Parallel Key | | | | | |
|-------|-------|---------------|--------------------------|------------------------------------|--|-------------------------------|---------------------------------------|---------------------------------------|---------------------------------------|-----|-----|
| above | Up to | t in shaft | t ₁ in hub | R ₁ keyway radius | R ₂ chamfer or radius of key | b x h width x height | P9 tolerance on keyway width | L _{min} minimum length | L _{max} maximum length | | |
| 6 | 8 | 1.1 | 0.9 | 0.2 | 0.25 | 2 x 2 | - 0.009 | 9 | 20 | | |
| 8 | 10 | 1.7 | 1.3 | | | 3 x 3 | - 0.034 | 9 | 36 | | |
| 10 | 12 | 2.4 | 1.6 | 0.4 | 0.5 | 4 x 4 | - 0.012 | 10 | 45 | | |
| 12 | 17 | 2.9 | 2.1 | | | 5 x 5 | | - 0.042 | 12 | 56 | |
| 17 | 22 | 3.5 | 2.5 | | | 6 x 6 | - 0.015 | 16 | 70 | | |
| 22 | 30 | 4.1 | 2.9 | + 0.2 + 0.1 | 0.6 | 8 x 7 | - 0.051 | 20 | 90 | | |
| 30 | 38 | 4.7 | 3.3 | | | 10 x 8 | - 0.018 | 25 | 110 | | |
| 38 | 44 | 4.9 | 3.1 | + 0.2 0.0 | 0.7 | 12 x 8 | - 0.018 | 32 | 140 | | |
| 44 | 50 | 5.5 | 3.5 | | | 14 x 9 | | - 0.061 | 40 | 180 | |
| 50 | 58 | 6.2 | 3.8 | | | 16 x 10 | - 0.022 | 45 | 200 | | |
| 58 | 65 | 6.8 | 4.2 | | | 18 x 11 | | - 0.074 | 50 | 220 | |
| 65 | 75 | 7.4 | 4.6 | + 0.4 + 0.2 | 1.0 | 20 x 12 | - 0.022 | 56 | 250 | | |
| 75 | 85 | 8.5 | 5.3 | | | 22 x 14 | | - 0.061 | 63 | 280 | |
| 85 | 95 | 8.7 | 5.5 | + 0.3 + 0.3 | 1.6 | 25 x 14 | - 0.026 | 70 | 315 | | |
| 95 | 110 | 9.9 | 6.1 | | | 28 x 16 | | - 0.088 | 80 | 355 | |
| 110 | 130 | 11.1 | 6.9 | | | 32 x 18 | - 0.032 | 90 | 355 | | |
| 130 | 150 | 12.3 | 7.7 | 36 x 20 | - 0.106 | 100 | | 355 | | | |
| 150 | 170 | 13.5 | 8.5 | + 0.6 + 0.3 | 2.0 | 40 x 22 | - 0.026 | 110 | 400 | | |
| 170 | 200 | 15.3 | 9.7 | | | 45 x 25 | | - 0.088 | 120 | 400 | |
| 200 | 230 | 17.0 | 11.0 | + 0.3 0.0 | 1.6 | 50 x 28 | - 0.032 | 130 | 400 | | |
| 230 | 260 | 19.3 | 12.4 | | | 56 x 32 | | - 0.032 | 140 | 400 | |
| 260 | 290 | 19.6 | 12.7 | | | 2.5 | 3.0 | 63 x 32 | - 0.106 | 140 | 400 |

Length of key: 9, 10, 12, 14, 16, 18, 20, 22, 25, 28, 32, 36, 40, 45, 50, 56, 63, 70...(by 10)...110, 125, 140, ...(by 20)...220, 250, 280, 315, 355, 400 mm.

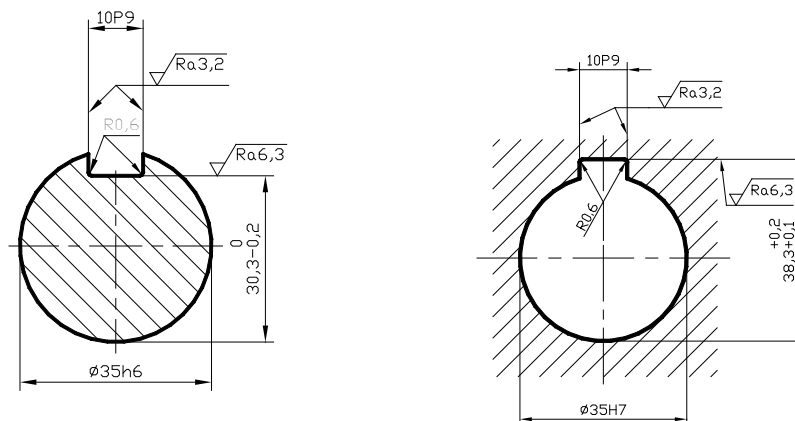

Keyway in shaft and in hub - example of dimensioning